

Features

- Solid state, high reliability
- Standard TO-8 package suitable for PC board mount
- Low cost, small size
- Available in gauge, absolute, and differential pressure versions
- Media compatible with non-corrosive gases and dry air
- Typical FSO 100 mV @ 1.5 mA
- Thermal accuracy FSO 0.4% typical
- Overpressure capability to five times maximum rated pressure
- Three standard ranges: 15, 30 and 100 psi (1, 2 and 7 bar)
- Nonlinearity 0.05% FSO typical
- Standard 3/16 in OD pressure port
- Ceramic substrate with temperature compensation resistors

Applications

- Process control, P-to-I converters
- Pneumatic control systems
- HVAC controls
- Biomedical: Infusion pumps, sphygmomanometers, respirators
- Aerospace: Altimeters, barometers, cabin pressure sensors
- Computer peripherals

NPH Series

NovaSensor Solid State Medium Pressure Sensors

NPH Series is a NovaSensor product. NovaSensor has joined other GE high-technology sensing businesses under a new name—GE Industrial, Sensing.



NPH Series Specifications

Description

An integrated circuit silicon sensor chip is housed in a standard TO-8 electrical package that is printed circuit board mountable.

The latest techniques in micromachining have been used to ion-implant piezoresistive strain gauges into a wheatstone bridge configuration that is integrally formed on a micromachined silicon diaphragm. As with all NovaSensor silicon sensors, the NPH Series employs SenStable® processing technology, providing excellent output stability. Constant current excitation to the sensor produces a voltage output that is linearly proportional to the input pressure.

The user can provide standard signal conditioning circuitry to amplify the 100 mV output signal. The sensor is compatible with most non-corrosive gases and dry air.

A laser-trimmed, thick-film resistor network on a hybrid ceramic substrate provides temperature compensation.

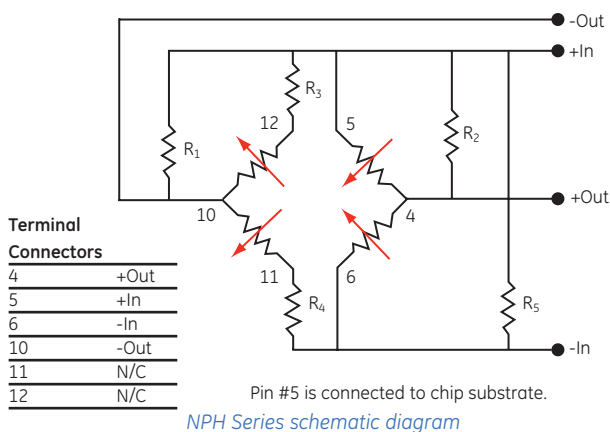

Parameter	Value	Units	Notes
General			
Pressure Range	0 to 15	psi	(0 to 1 bar) 0 to 100 kPa
	0 to 30	psi	(0 to 2 bar) 0 to 200 kPa
	0 to 100	psi	(0 to 7 bar) 0 to 700 kPa
Maximum Pressure	4x		rated pressure ⁽⁸⁾
Electrical @ 77°F (25°C) Unless Otherwise Stated			
Input Excitation	1.5	mA	2 mA maximum
Insulation Resistance	10 ⁸	Ω	@ 50 VDC
Input Impedance	4000	Ω	±20%
Output Impedance	5000	Ω	±20%
Bridge Impedance	5000	Ω	±20%
Environmental			
Temperature Range			
Operating ⁽⁹⁾	-40 to 257	°F	(-40°C to 125°C)
Compensated	32 to 158	°F	(0°C to 70°C)
Vibration	10	gRMS	20 to 2000 Hz
Shock	100	g	11 milliseconds
Life (Dynamic Pressure Cycle)	1 x 10 ⁶	cycles	
Mechanical⁽¹¹⁾			
Weight	<0.2	oz	(<5 g)
Media Compatibility	Non-corrosive gases and clean, dry air		
Wetted Materials			
Top Port	Nickel, gold plated Kovar, silicone gel, gold wire, RTV, silicon and glass.		
Bottom Port	Gold plated Kovar, silicon, glass and RTV ⁽¹⁰⁾		

Parameter	Units	Minimum	Type	Maximum	Notes
Performance Parameters⁽⁷⁾, Compensated⁽⁴⁾, 100, 200 and 700 kPa					
Offset	mV	-2	1	2	
Full Scale Output	mV	75	100	125	2
Linearity	%FSO	-0.1	0.05	0.1	3
Hysteresis and Repeatability	%FSO	-0.05	0.01	0.05	
Thermal Accuracy of Offset					
100 kPa	%FSO	-0.6	0.4	0.6	4
200 and 700 kPa	%FSO	-0.5	0.2	0.5	4
Thermal Accuracy of FSO					
100 kPa	%FSO	-0.6	0.4	0.6	4
200 & 700 kPa	%FSO	-0.5	0.2	0.5	4
Thermal Hysteresis	%FSO	-0.1	0.05	0.1	5
Short-Term Stability of Offset	μV/V		5		6, 11
Short-Term Stability of FSO	μV/V		5		6, 11

1. Performance with offset, thermal accuracy of offset, and thermal accuracy of FSO compensation resistors.
2. FSO with 1.5 mA input excitation.
3. Best fit straight line.
4. 32°F to 158°F (0°C to 70°C) with reference to 77°F (25°C)
5. 32°F to 158°F (0°C to 70°C), by design.
6. Normalized offset/bridge voltage—100 hrs, typical value, not tested in production.
7. All values at 77°F (25°C) and at 1.5 mA, unless otherwise noted.
8. Topside pressure. Backside pressure maximum pressure is 250 psi (17.23 bar) or 4x rated pressure, whichever is less.
9. Reduced performance outside compensation range.
10. Backside differential tube is nickel or Kovar.
11. Typical specifications are for reference only; absolute values may vary.

NPH Series Specifications

Ordering Information

The code number to be ordered may be specified as follows:

NPH	
Code	Package Configuration
8	TO-8
Code	Pressure Range (kPa)
100	100 kPa; 15 psi (1 bar)
200	200 kPa; 30 psi (2 bar)
700	700 kPa; 100 psi (7 bar)
Code	Pressure
A	Absolute (30 kPa only)
G	Gauge
D	Differential
Code	Compensation
H	Hybrid substrate
<p>NPC- - - - - Typical model number</p>	

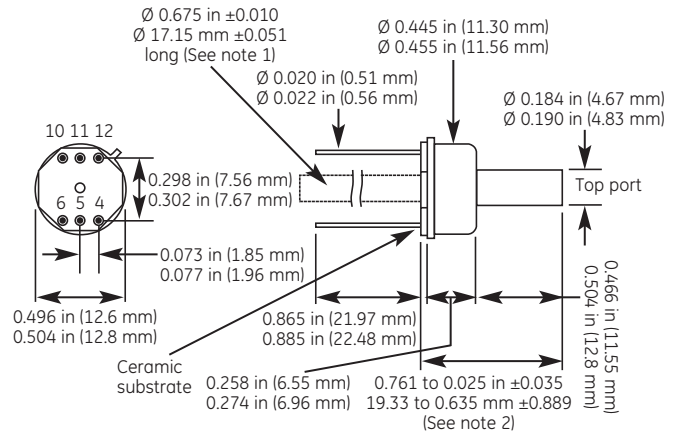

Pin	Function
4	+Out
5	+In
6	-In
10	-Out

- Backside differential tube is 17.15 ± 0.051 (0.675 ± 0.010) long, measured from back of header to tip, not from backplane of ceramic to tip.
- Length is 19.33 -0.635/+0.889 (0.761 -0.025/0.035) for gauge type and 19.33 -0.635/1.40 (0.761 .025/+0.055) for differential type.

NPH Series package diagram

GE
Sensing



©2006 GE. All rights reserved.
920-314A

All specifications are subject to change for product improvement without notice.
GE® is a registered trademark of General Electric Co. Other company or product
names mentioned in this document may be trademarks or registered trademarks
of their respective companies, which are not affiliated with GE.

www.gesensing.com