

# GE Sensing

## Features

- Available as a broad range of resistances and material systems
- High sensitivity to changes in temperature
- Suitable for probe mounting
- Normally used for gauge driving under self-heated conditions
- Wide operating temperature range: -58°F to 311°F (-50°C to 155°C)
- Rugged construction
- Proven quality and reliability over many years of manufacturing
- Excellent stability

## Applications

Typical applications include automotive engine temperature gauge driving.

---

# NTC Unleaded Disc

## Thermometrics Thermistors

NTC Unleaded Disc is a Thermometrics product. Thermometrics has joined other GE high-technology sensing businesses under a new name—GE Industrial, Sensing.



# Type KU Specification

Unleaded disc

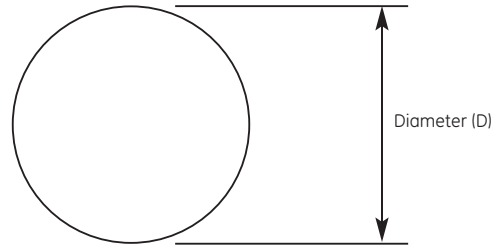

## Description

A range of unleaded disc thermistors.

## Options

- Other resistance-temperature characteristics
- Custom design to match gauge characteristics
- 'Washer' configuration with central hole

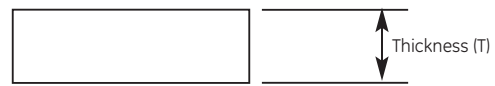

NTC Type KU dimensions

## Data

Part No.	R60 Nominal Ω	R85 Nominal Ω	R115 Nominal Ω	Tref °C	Rref		Diameter D		Thickness T	
					Nominal Ω	Tolerance ±%	Nominal in (mm)	Tolerance in (±mm)	Nominal in (mm)	Tolerance in (±mm)
K1	61	21.5	7	126	5.2	5.80	0.20 (5.30)	0.007 (0.20)	0.04 (1.20)	0.003 (0.10)
K2	366	119	37	126	25.6	4.25	0.09 (2.50)	0.004 (0.12)	0.03 (0.94)	0.04 (1.04)
KU28	233	102.7	44	121.1	37.7	5.00	0.19 (4.89)	0.01 (0.32)	0.06 (1.65)	0.02 (0.64)
KU29	61	29	14	132	9.6	4.20	0.19 (4.88)	0.01 (0.32)	0.06 (1.53)	0.02 (0.51)
KU34	47	23	11	115.6	10.7	6.50	0.19 (4.88)	0.01 (0.32)	0.05 (1.51)	0.01 (0.50)
KU41	114	38	13	122	9.9	8.70	0.19 (4.88)	0.01 (0.32)	0.06 (1.66)	0.02 (0.65)
KU44	367	118	34	113	37.1	5.00	0.19 (4.85)	0.013 (0.35)	0.06 (1.75)	0.02 (0.75)
KU46	157	65	26	100	40.8	8.00	0.19 (4.88)	0.013 (0.35)	0.06 (1.75)	0.02 (0.75)
KU50	250	79	24	110	28.7	3.80	0.19 (4.95)	0.01 (0.45)	0.06 (1.75)	0.02 (0.75)
KU57	70	24	8	100	13.5	5.50	0.25 (6.53)	0.009 (0.25)	0.07 (1.93)	0.05 (1.29)
KU60	550	117	107	100	144.0	3.50	0.24 (6.10)	0.007 (0.20)	0.04 (1.20)	0.01 (0.30)
KU61	116	52.3	23	126	16.5	7.90	0.19 (4.88)	0.01 (0.32)	0.06 (1.75)	0.02 (0.75)
KU62	185	84	30	85	84.0	3.00	0.19 (5.00)	0.01 (0.30)	0.06 (1.75)	0.01 (0.40)
KU64	96.5	45	20	100	29.5	5.00	0.22 (5.70)	0.01 (0.29)	0.05 (1.35)	0.01 (0.27)
KU66	197	82	32.6	85	81.8	8.20	0.19 (5.00)	0.01 (0.30)	0.06 (1.75)	0.01 (0.40)
KUS2503	535	230	101	100	150.0	8.00	0.19 (5.00)	0.01 (0.30)	0.05 (1.50)	0.01 (0.50)
KUS2581	181	56	17	100	30.0	10.00	0.23 (6.00)	0.01 (0.20)	0.04 (1.25)	0.01 (0.20)
KUS2695	396	120	34	115	34.4	4.70	0.19 (5.00)	0.01 (0.30)	0.05 (1.30)	0.01 (0.20)
KUS2985	185	84	30	100	50.2	4.76	0.19 (5.00)	0.01 (0.50)	0.06 (1.75)	0.02 (0.75)
KUS2910	666	281	115	132.2	72.7	1.60	0.19 (4.89)	0.01 (0.32)	0.05 (1.48)	0.01 (0.13)
KUS2912	613	259	106	132.2	67.0	1.60	0.19 (4.89)	0.01 (0.32)	0.05 (1.48)	0.01 (0.13)
KUS303	168	75	32	100	45.0	8.00	0.24 (6.10)	0.01 (0.26)	0.07 (1.93)	0.01 (1.29)
KUS304	199	89	38	100	53.3	9.00	0.24 (6.10)	0.01 (0.26)	0.07 (1.93)	0.01 (1.29)
KUS3081	565	239	97	100	150.0	5.00	0.19 (4.89)	0.01 (0.32)	0.05 (1.48)	0.01 (0.13)
KUS3337	550	117	107	96.5	160.0	5.00	0.19 (5.05)	0.02 (0.55)	0.05 (1.50)	0.01 (0.50)
KUS3891	158	70	30	100	45.0	4.00	0.21 (5.50)	0.01 (0.30)	0.04 (1.10)	0.01 (0.30)
KUS4047	557	231	93	100	144.0	5.00	0.21 (5.50)	0.01 (0.50)	0.04 (1.15)	0.01 (0.40)
KUS4104	661	279	114	110	131.2	4.00	0.18 (4.60)	0.01 (0.30)	0.60 (1.60)	0.01 (0.25)
KUS4161	679	287	117	128	82.7	2.00	0.19 (4.89)	0.01 (0.32)	0.05 (1.53)	0.01 (0.38)

# Type UD20 Specification

Unleaded disc

## Description

Unleaded disc thermistor for engine temperature measurement.

## Options

- Other resistances
- Other tolerances, tolerances at other temperatures
- Alternative sizes and configurations
- Alternative material systems and resistances

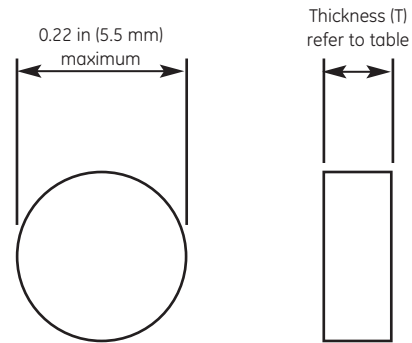

NTC Type UD20 dimensions

Type Number	$\beta$ 25/85	Material System	R@100C ( $\pm 5\%$ )	R@125C (Ref.)	R@25C (Ref.)	Thickness In (mm) T
2006-86.6-70-UD	3394	S7.0	13.80	7.59	137.2	0.06 (1.5)
2006-122-76-UD	3541	S7.6	18.00	9.66	197.6	0.06 (1.5)
2005-125-73-UD	3468	D7.3	19.16	10.42	200.2	0.05 (1.3)
2006-138.9-78-UD	3600	S7.8	20.00	10.67	226.5	0.06 (1.5)
2006-165.7-81-UD	3658	S8.1	23.00	12.16	273.1	0.06 (1.5)
2007-175.1-85-UD	3772	D8.5	23.21	12.38	294.5	0.07 (1.8)
2006-184.1-83-UD	3704	S8.3	25.00	13.14	305.4	0.06 (1.5)
2006-213.7-86-UD	3773	S8.6	28.00	14.65	357.9	0.06 (1.5)
2006-256.0-89-UD	3837	S8.9	32.50	16.83	432.8	0.06 (1.5)
2006-300.1-92-UD	3901	S9.2	37.00	18.98	513.1	0.06 (1.5)
2006-364.7-77-UD	3592	D7.7A	52.14	27.88	593.4	0.06 (1.5)
2006-450.0-97-UD	3993	S9.7	52.60	26.61	777.3	0.06 (1.5)
2006-484.1-100-UD	4045	S10.0	55.00	27.58	842.1	0.06 (1.5)
2005-1272-245-UD	5585	HL24.5	61.82	23.36	2711	0.05 (1.3)
2006-719.3-105-UD	4125	S10.5	78.00	38.66	1266	0.06 (1.5)
2004-1K-115-UD	4284	S11.5	99.48	47.95	1796	0.04 (1.0)
2006-983.1-109-UD	4190	S10.9	103.0	50.5	1745	0.06 (1.5)
2006-412-41-UD	2489	B4.1	104.8	66.2	571.9	0.06 (1.5)
2006-1120-107-UD	4161	S10.7	119.2	58.58	1980	0.06 (1.5)
2006-1167-111-UD	4223	S11.1	120.0	58.5	2079	0.06 (1.5)
2006-1355-113-UD	4253	S11.3	137.0	66.4	2424	0.06 (1.5)
2006-1600-103-UD	4073	D10.3	177.5	88.05	2786	0.06 (1.5)
2006-2010-118-UD	4329	S11.8	195.0	93.3	3630	0.06 (1.5)
2006-2753-120-UD	4356	D12.0	263.3	125.5	5000	0.06 (1.5)
2006-3K-123-UD	4396	S12.3	280.0	132.4	5466	0.06 (1.5)
2006-4240-125-UD	4423	S12.5	389.9	182.9	7756	0.06 (1.5)
2006-4444-128-UD	4462	S12.8	400.0	185.9	8170	0.06 (1.5)
2006-5679-131-UD	4501	S13.1	500.0	230.2	10488	0.06 (1.5)
2006-8240-134-UD	4541	S13.4	709.4	324.8	15284	0.06 (1.5)
2006-9186-137-UD	4586	S13.7	775.0	351.6	17120	0.06 (1.5)
2006-13.3K-140-UD	4615	D14.0	1100	495.7	24923	0.06 (1.5)
2006-14.8K-143-UD	4649	S14.3	1200	536.2	27811	0.06 (1.5)
2006-18.6K-146-UD	4685	S14.6	1475	655.2	35060	0.06 (1.5)
2006-21.7K-148-UD	4701	S14.8	1700	751.9	41023	0.06 (1.5)
2006-27.53K-150-UD	4728	D15.0	2133	939.9	52220	0.06 (1.5)
2006-30.1K-152-UD	4750	S15.2	2300	1008	57170	0.06 (1.5)
2006-38.0K-155-UD	4783	D15.5	2850	1243	72493	0.06 (1.5)

GE  
Sensing



©2006 GE. All rights reserved.  
920-326A

All specifications are subject to change for product improvement without notice.  
GE® is a registered trademark of General Electric Co. Other company or product  
names mentioned in this document may be trademarks or registered trademarks  
of their respective companies, which are not affiliated with GE.

[www.gesensing.com](http://www.gesensing.com)